

Mass Properties Measurement Errors Which Could Have Been Easily Avoided

by

Richard Boynton, President
Space Electronics, Inc.
81 Fuller Way
Berlin, Connecticut 06037
(860) 829-0001

For presentation at the
58th Annual Conference
of the
Society of Allied Weight Engineers

San Jose, California, May 24-26, 1999

Permission to publish this paper, in full or in part, with full
credit to author may be obtained by request to:

S.A.W.E., Inc.
5530 Aztec Drive
La Mesa, CA 91942-2110

Company and Government clearance, as appropriate, is solely the responsibility of the author.
Opinions expressed in technical papers or discussions at meetings are those of the author and do not
necessarily reflect those of the society.

Abstract This paper contains a description of actual case histories of instances where a mass properties measurement error has occurred which could have been avoided (no names mentioned!). Some of these errors resulted from fundamental defects in the procedure; others resulted from very subtle effects which would have been hard to anticipate. And others are painfully obvious, once you realize the problem. However, the fact that these errors occurred emphasizes the need to have a check list, and to have a person who is knowledgeable in mass properties supervising the measurement.

The purpose in publishing this history of real errors is to help you avoid these pitfalls. Many of us have made these mistakes (sometimes more than once). We hope that persons reading this paper will supply additional examples to the author, so that I can publish a sequel to this in the future.

CASE #1 A Multiple Scale System Which Didn't Work A company did not have a single scale which was large enough to weigh a vehicle, so the solution was to place three scales under a platform to create a larger scale. The vehicle was placed on the platform, and then the three scale readouts were added. When this method had been devised, it was hoped that a crude measurement of center of gravity could be obtained from the difference in the scale readings (if all three scales read the same amount, the cg was midway between the scales, etc). However, when this measurement was attempted, it was impossible to get repeatable readings. The combined weight would change when the vehicle was moved from one place to another on the platform, and the measured cg did not agree with the distance the vehicle was moved on the platform. In other words, if the vehicle was moved by 1 inch in the X direction, the calculated cg did not change by 1 inch.

The first step in identifying the problem was to have the three scales calibrated. They were sent to the lab, and they all were shown to have errors which were less than 0.05%, yet the sum of the three readings had varied by more than 1%!

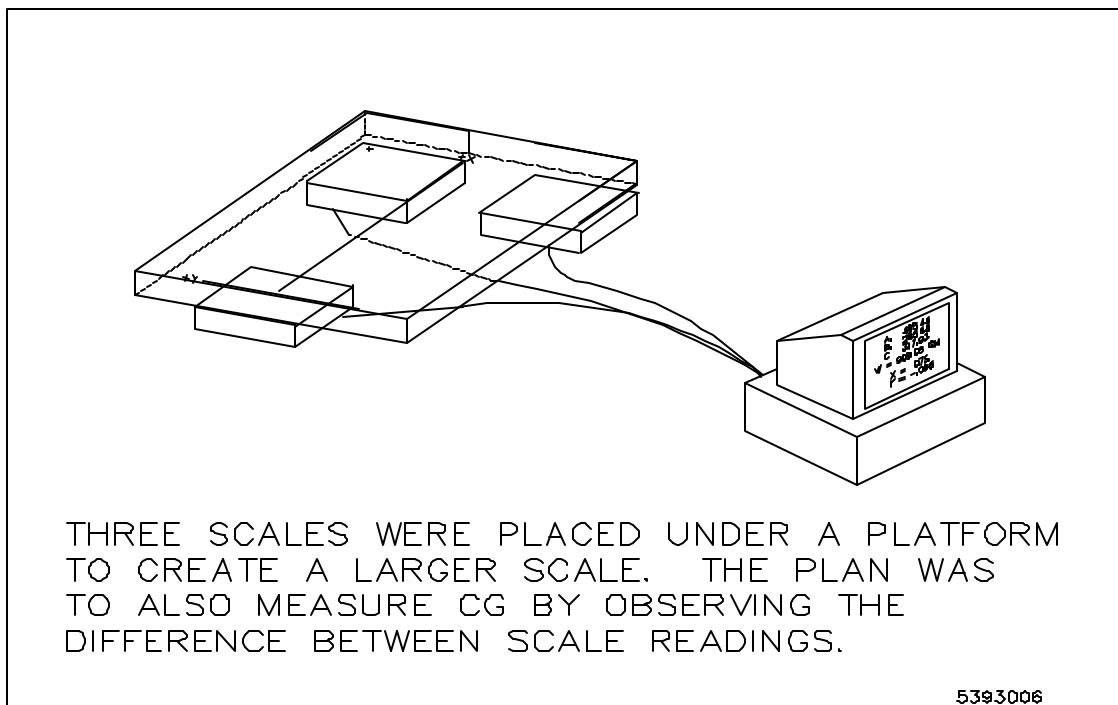

The second step in identifying the problem was to re-assemble the platform and place large test weights on it. The readings changed when the weights were moved. In addition, the total measured weight was larger than it should be. What was wrong??

{Answer}: Scales are not made to be linked together. In order to get accurate readings, a scale must float freely and not have any side load. Some scales are more sensitive to this problem than others. In this particular case there was another problem: the thin platform was bending under the weight of the vehicle, so that it was not square with the top of the scale, and presented a different side load when the vehicle was moved from one position to another. **(See Appendix for more information).**

Lesson learned: Scales cannot be linked together. They are only accurate when operated independently.

CASE #2 Multiple Load Cell CG Problems The next attempt in measuring the same vehicle was to hang the vehicle platform from three load cells. Since the roof of the building was not strong enough to support the weight of the vehicle, a structure had to be constructed. The three load cells were attached to this structure, and the platform was hung from three cables. Flexures were used on either end of the load cells to make sure there was no bending moment (this organization was not going to make the same mistake twice). When the vehicle was measured, the measured weight was constant, no matter what position the vehicle was placed on the platform. Success! But wait a minute: when the vehicle was moved 1 inch, the calculated cg position moved much more than 1 inch. Now what was wrong? How could the cg be in error when the total weight appeared to be correct?

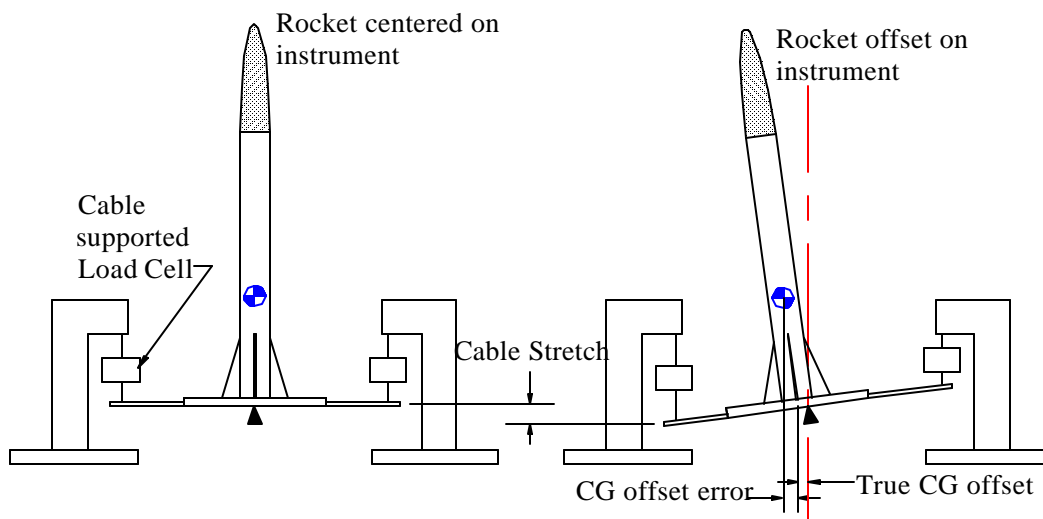

Cable stretch causes the Rocket CG to lean outward, increasing CG offset.

{Answer}: The cables were stretching, causing the vehicle to lean. Since the vehicle cg was considerably above the platform, the cg would move outward when the cable stretched, amplifying the cg offset. This was determined by placing a level on the platform, and then moving the vehicle to a new position.

Lesson learned: Multiple-point cg measurements require a rigid force measurement system. Otherwise, the cg of the object will lean outward, amplifying the cg offset.

CASE #3 The Levitating Satellite which Turned Cartwheels It is essential that the center of gravity of a satellite be exactly in line with the centerline of the thrusters. Otherwise, when the thruster is fired, a torque will be created which causes the satellite to spin rather than translate its position. In this particular tragic case, a satellite test platform had been constructed to demonstrate the operation of a new control concept. In this experiment, the test satellite was to be dropped above a net, and the thrusters were to be fired while the satellite was in midair. It was expected that the satellite would be suspended in air and could be maneuvered above the net for a number of seconds. High level government personnel were present to witness the test. The day prior to making the test, the center of gravity had been measured and correction weights were added to move the CG to the exact centerline. Unfortunately, no one thought to re-measure the cg after the weights had been added. They had been added to the wrong side, doubling the cg offset, rather than trimming it to zero. At the appointed moment, the high-speed video cameras were started, and the satellites was dropped. Instead of levitating above the net, it instantly went into a spin.

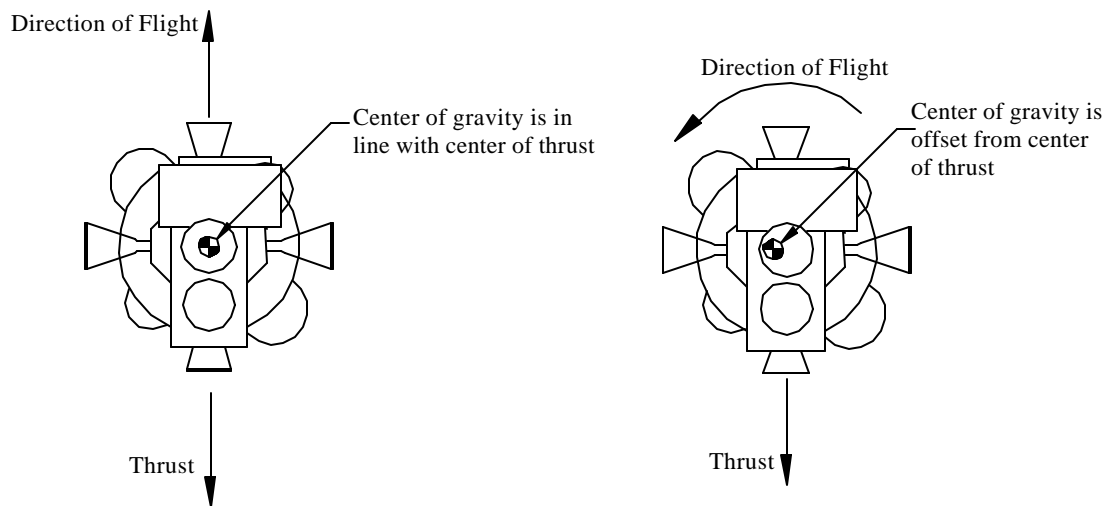

Lesson learned: Always re-measure a vehicle after weight correction has been performed to make sure that the correction was successful.

CASE #4 Turbine Blade Fixturing Error Two facilities were measuring the moment weight of the same type of blade. There was a consistent difference between the measurements made by the two facilities, so that blades measured by one could not be mixed with blades measured by the other when assembling the jet engine rotor. It turned out that the adapter had been assembled differently at the two facilities. At one location, the adapter spring caused the turbine blade to be forced forward. At the other facility, the adapter forced the blade backward. Which one was correct?

{Answer} Centrifugal force pulls the blade forward when it is spinning in the engine. Therefore, the blade should be forced forward in the adapter. The design used by company B is correct.

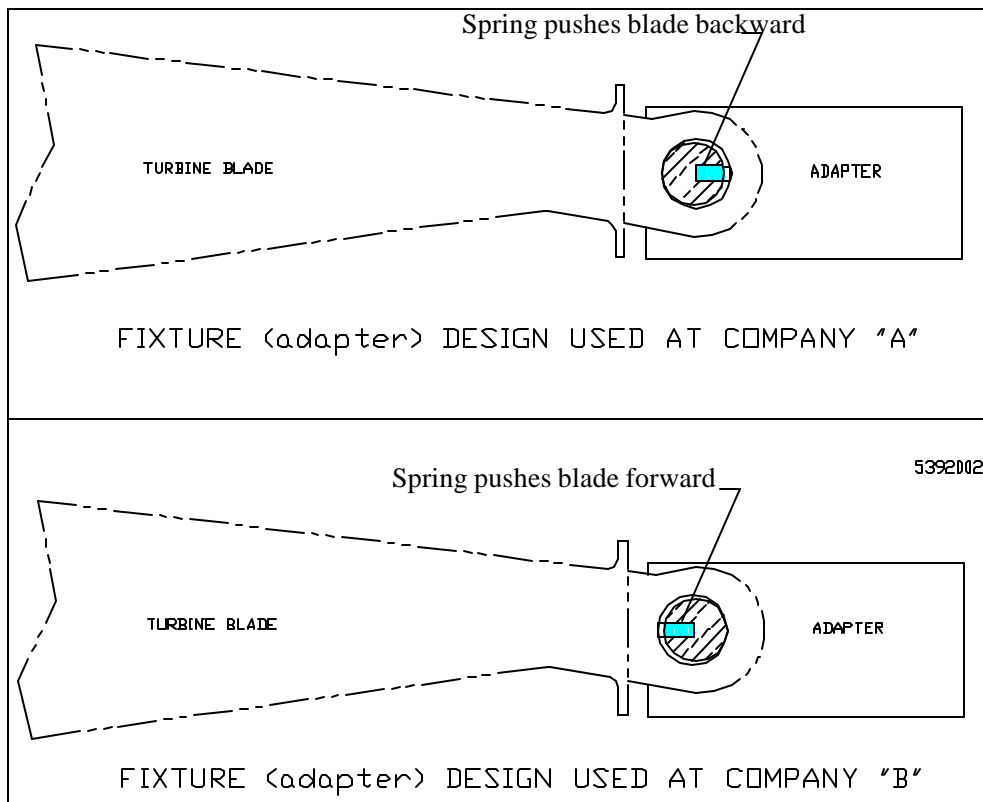

CASE #5 Another Turbine Blade Fixturing Error Turbine blades in a jet engine must be sorted by cg moment. Pairs of blades with identical moment are installed in the engine 180 degrees from each other, so that the unbalance is minimized. A jet engine manufacturer was sorting these blades with what he thought was a high precision, yet the engines were badly unbalanced after the blades were installed.

The problem was the point of contact of the blades with the adapter that was used in the moment measuring scale. In an engine, centrifugal force pulls the blades outward until the root of the blade contacts the hub of the engine. The engine manufacturer was contacting these blades at a different point during his static moment measurement.

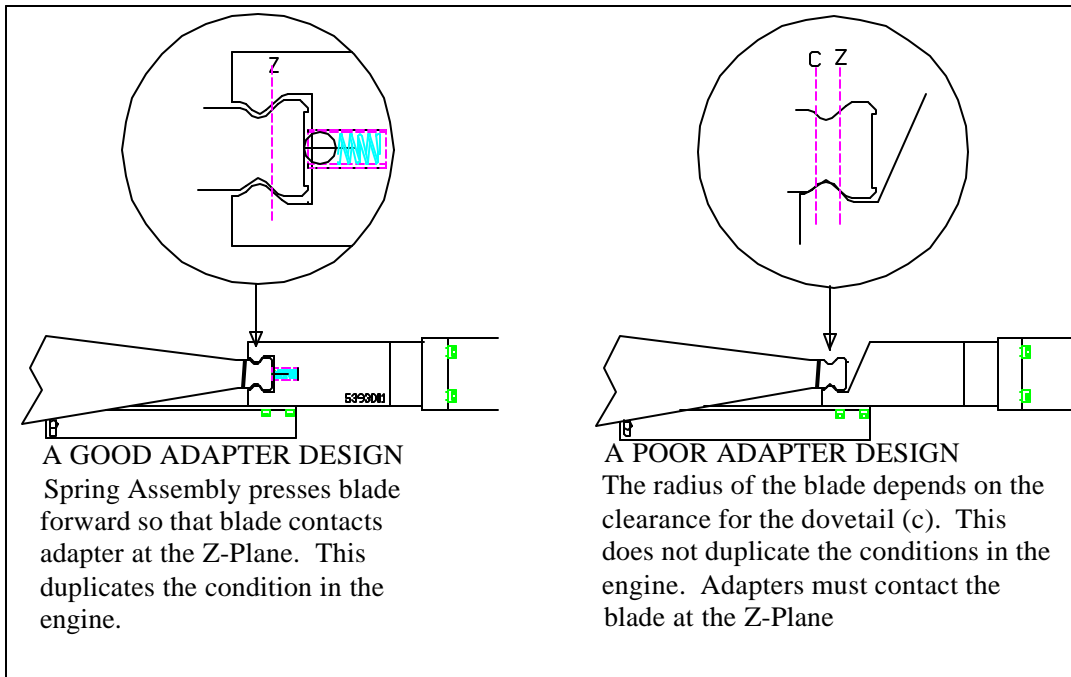

CASE #6 The Case of the Errant Allen Wrench A company did a statistical analysis on the center of gravity data for a particular object, and they discovered that the first shift operator consistently got an X axis cg location which was about 1/8 inch different from the second shift operator. To verify this observation, they had the first shift operator and the second shift operator both measure the same object. Sure enough, this measurement was also 1/8 inch different. An engineer was assigned to determine the cause of this difference. The illustrations on the next page give a clue to one part of the problem. As you can see, operator #2 put the Allen wrench on his workbench after tightening the screws which mounted the object to the fixture. Operator #1 put the Allen wrench in a hole in the fixture. This was a handy place to keep the Allen wrench, but unfortunately it added an unbalance mass to the measurement. Since the tare CG had been determined without the Allen wrench, this mass caused a consistent cg error on his measurements.

At first, it appeared that the problem had been solved. However, after the correct procedure was established for storing the Allen wrench, the cg data was still different between operator #1 and operator #2. What was going on? The illustration below of the configuration during tare measurement gives a clue to the answer:

{Answer}: Operator #2 included the mounting screws in the tare measurement, because he reasoned that these screws were not part of the object, and therefore should be left in place during tare measurement so their contribution to unbalance moment would be subtracted from the object measurement. Operator #1 left these screws out during tare measurement. Although operator #1 was careless about his location for the Allen wrench, he made the right decision about the mounting screws. These are installed during flight and therefore constitute part of the object.

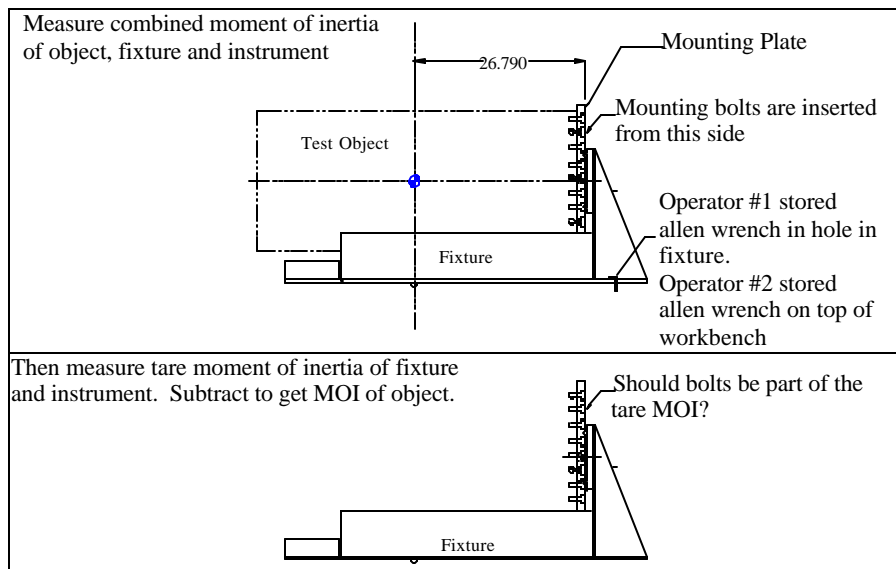

Lesson learned: You must make a decision whether the mounting hardware is part of the object or unique to the fixturing method. If it is part of the object, then it should be removed during tare measurement. Don't leave any loose items such as wrenches on the fixture during measurement.

CASE #7 Difference in MOI between Measurement on Earth and Flight in Space The moment of inertia of a satellite was measured in a lab prior to flight. After the satellite was placed in orbit, the response to thruster correction seemed to indicate that the MOI of the satellite was smaller than measured on earth. What was the reason?

{Answer}: For large lightweight payloads, the measured mass properties in air are often significantly different from the values in the vacuum of space. In particular, measured moment of inertia can be 10% to 20% larger than calculated. The reason for this is that air has significant mass and alters the mass properties in two ways:

Air trapped **inside** the payload will increase its mass by an amount equal to the unoccupied volume in the payload times the density of air (0.0754 pounds per cubic foot). For example, the air trapped in a 6 foot diameter satellite might weigh approximately 4 lbs. We call this the entrapped air effect.

Air dragged or pushed along by any protrusions on the outer surface of the payload can dramatically increase moment of inertia. For example, the roll moment of inertia of an aircraft flying at sea level is larger than the roll MOI of the aircraft at 40,000 feet. We call this the entrained air effect.

If the payload flies in a vacuum, then measured values must be decreased to eliminate the effect of air mass. The best way of doing this is to make a second measurement in helium and then extrapolate the value in vacuum (see SAWE paper No. 2024 by Boynton and Wiener). Or if you have a vacuum chamber which is large enough to accommodate the satellite and mass properties machine, you can measure the satellite in a vacuum. However, this requires special modifications to the mass properties machine.

CASE #8 Does Room Size Affect Measurement Accuracy? The moment of inertia of an airfoil was measured in a small experimental lab. Readings were very repeatable. However, when the machine was moved to the large production floor with a 60 foot high ceiling, it was impossible to get consistent readings. This area had an overhead door which led to the outside of the building, but the door was always closed before measurements were made, and the air conditioner was shut off to prevent drafts. Why was repeatability worse in a larger room?

{Answer}: The problem turned out to be air inversion. If the overhead door was opened for even a short interval, warm air entered the building at the ground level. Meanwhile, cool air was leaving the A/C duct at the ceiling of the building. This created an inversion layer. The warm air continued to rise long after the

overhead door was shut, creating drafts which acted on the airfoil section.

CASE #9 Importance of Axis Definition The cg of a 22 inch long projectile was measured at one facility. The cg machine and the fixture were then shipped to another facility and the measurement was repeated. By analyzing the data, see if you can figure out why the answers were different.

<p>Measurement # 1</p> <p>CGX = 10.5 inch (axial)</p> <p>CGY = -0.050 inch (radial)</p> <p>CGZ = +0.030 inch (radial)</p>	<p><u>Measurement # 2</u></p> <p>CGX = 11.5 inch (axial)</p> <p>CGY = +0.050 inch (radial)</p> <p>CGZ = -0.030 inch (radial)</p>
---	--

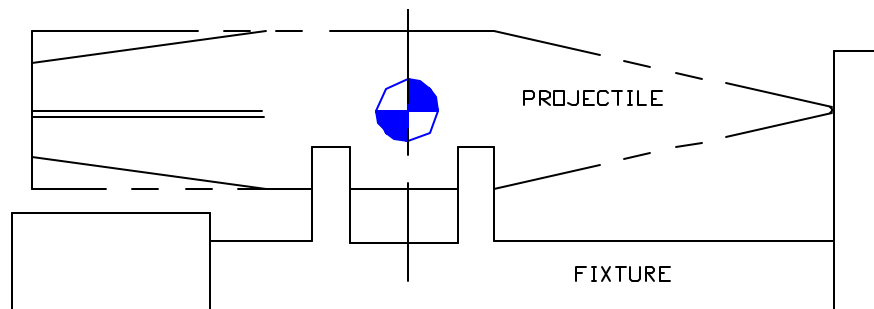

This fixture is designed to contact the nose of the projectile

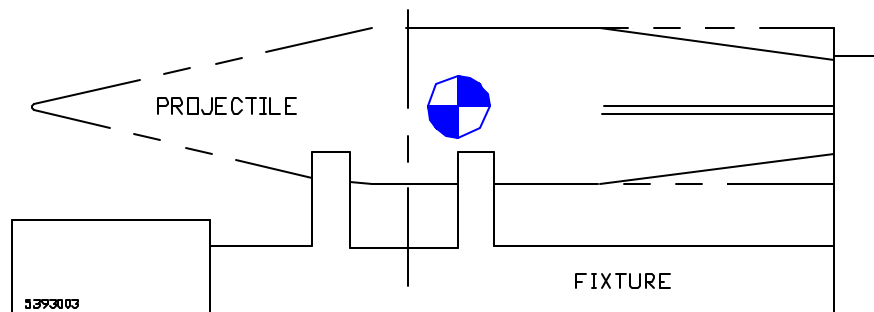

If the projectile is placed in the fixture backwards, then all CG data will be in error.

(Answer): The nose of the projectile contacted the fixture end stop in measurement #1, whereas the aft end of the projectile contacted the fixture end stop in measurement #2. When the cg measurement specification was reviewed, it turned out that it did not define which end was the reference. Therefore, each measurement technician inserted the projectile in the direction that seemed logical to him.

Lesson learned: Measurement specifications must define the axes! Use the SAWE Recommended Practice #6 Standard Coordinate System whenever possible.

CASE #10 Misjudging the Effect of Electrical Cable Weight We sold a gimbal balance machine to a company overseas. This instrument measures the CG of a seeker with extraordinary precision. We can detect an unbalance of 0.0001 lb-inch. Soon after we sold the gimbal balance machine, we learned that the customer was having a problem with repeatability. I visited this customer and discovered that he had attached a 1/4 inch diameter cable to the part he was measuring. The cable was hanging over the side of the machine, producing a moment that was about 1000 times what he was allowed. He had recognized this problem and had added a weight to the gimbal to compensate. What he didn't realize was that a minute motion of the cable would produce a change in moment that was at least 10 times his tolerance.

Several years later, the problem reappeared. He had learned to avoid attaching anything to the gimbal and was mystified that the repeatability problem was back. The difficulty turned out to be the cables inside a new type of gimbal. Numerous heavy cables had been run from the rotating assembly in the gimbal to the base of the gimbal. Therefore, the weight of the cables contributed to unbalance. A very small change in the position of these cables upset the balance. It was necessary to redesign the gimbal to eliminate this problem.

CASE #11 Protective Paper Used on the Face of a Gimballed Seeker Another company purchased a gimbal balance machine from Space Electronics for the measurement of a gimballed seeker. This seeker had a protective paper cover to prevent damage to the microwave antenna assembly. Balancing was performed with this paper in place. How much error could this paper have caused?

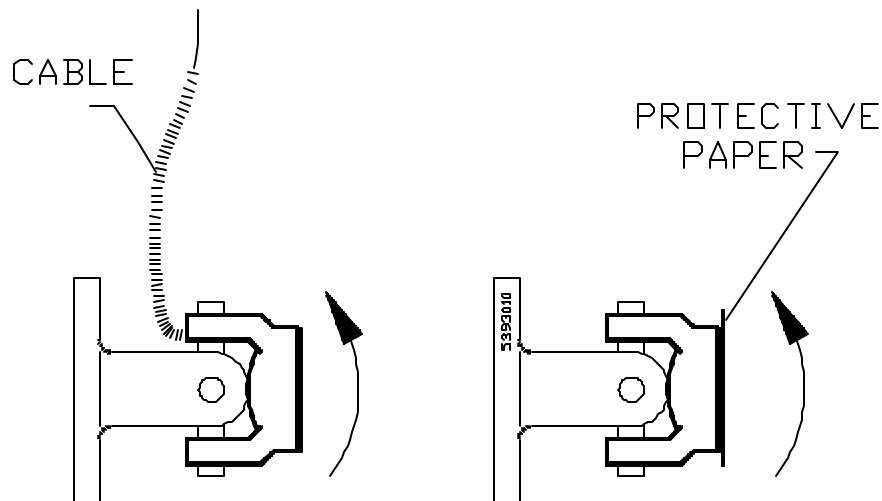

{Answer} Enough to make the seeker unbalance 10 times greater than the unbalance allowed.

CASE #12 Using Balancing Clay to Predict the Ballast Required This is a problem that we have seen many times. A vehicle is placed on a spin balance machine, and balancing clay is added to several locations on the vehicle skin until a balance is achieved. The position of these lumps of clay is then determined, and they are removed and weighed. Ballast weight are then fabricated. Their weight is identical to the lumps of balancing clay. The outer covers of the vehicle are then removed, and these weights are installed inside the vehicle. The vehicle covers are then re-installed, and a final spin balance measurement is performed. The measurement indicates that the weights were too light. Why?

{Answer}: The radius of the balancing clay is greater than the radius at which the ballast weight are

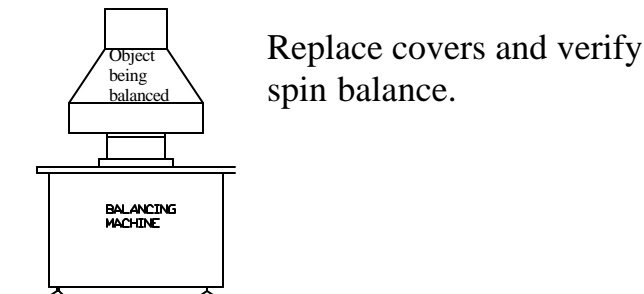
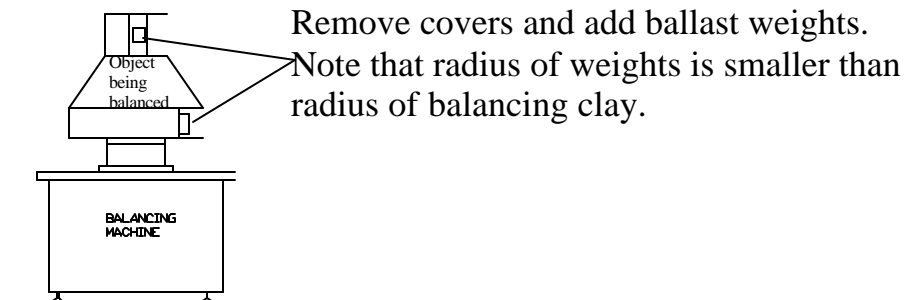
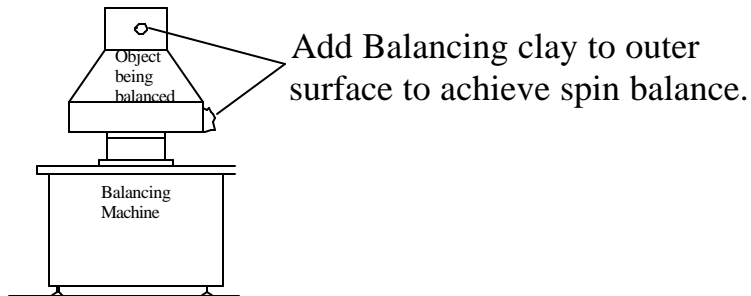

installed. Unbalance is proportional to the moment RW , where R is the radius to the CG of the ballast weight (or the CG of the balancing clay). Let's say that the initial unbalance was 100 lb-in^2 . Normally you might expect the unbalance after correction to be about 3 lb-in^2 . However, if the radius to the CG of the balancing clay was 12 inches, and the radius to the CG of the ballast weight was 9 inches, then the unbalance after correction will be 25 lb-in^2 , rather than 3 lb-in^2 . To avoid this problem, you must increase the ballast weight by the ratio of the balancing clay Cg radius divided by the ballast CG radius.

CASE #13 Unexpected Weight Gain This is the one situation which I was not personally involved in. This story was told to me by a member of the SAWE. The mass properties department of a certain company had been working overtime to lower the weight of a vehicle so it would meet the maximum weight specification. After weeks of design changes, a large number of components had been lightened considerably, yet when the entire vehicle was re-weighed, the total weight had increased! Teams of engineers met for several days to review the data and determine what had gone wrong. This could have continued for even longer, but someone happened to notice a red ribbon which had been neatly rolled up in the vehicle. When they unrolled it, it said “NOT FLIGHT ITEM”. It didn’t take long to find several other neatly rolled up streamers, all attached to work stands. When the work stands were removed, the vehicle was re-weighed and found to be within specification.

Lesson learned on Case #11 and Case #12: Make certain that non-flight items are removed before weighing.

Errors that No One would be Dumb Enough to Do (but they did)

1. A common method of achieving redundancy is to put two load cells in series. Since each is measuring the same force, they should agree within a small percentage. One mass properties engineer sent a work order to have the weight of several large objects measured, using a crane hook scale. The mass properties engineer was not given authorization to witness the measurement. When the data was sent to him, the values were almost exactly twice what he had calculated. What was wrong?
{Answer}: The test technician had added the readings from both load cells to get the total weight.

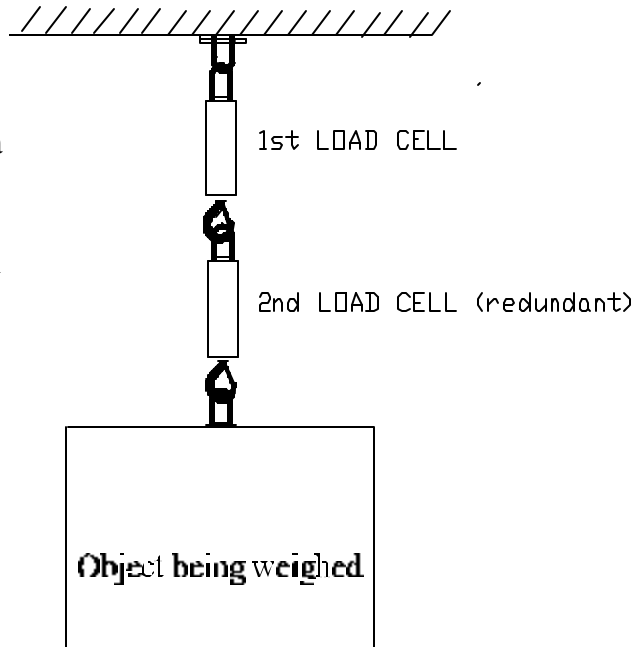

2. An accurate fixture is required to position a test object at a precisely known position relative to the mounting plate of a cg instrument. Fixturing inaccuracy is usually the major source of cg measurement error. However, occasionally we encounter an engineer who doesn’t even realize that a fixture is necessary. Someone called Space Electronics a number of years ago, after receiving a cg instrument. His complaint: “I can get any answer I want from your machine. It depends where I place my object on the cg instrument mounting plate. If I move the object by 1 inch, then the answer changes by 1 inch.”

3. If the radial cg of a projectile must be within 0.002 inch of the centerline, then the runout of the OD of the projectile must be less than 0.002 inch.. Otherwise, how do you define the centerline location? We received a shipment of projectiles and were asked to verify the measurement of the cg within 0.002 inch. Before measuring cg, we measured the runout of the OD, and found it to be 0.012 inch. Yet the customer had been able to determine that the projectile cg was within 0.001 inch on every sample. When we called the customer, he said “Oh, I place the projectile in the vee block fixture and then turn it until I find a position where I get the right answer!”

Lesson learned: Even if their rate of pay is low, it doesn't pay to use unqualified personnel.

Appendix

Why scales cannot be linked together mechanically without introducing error

Weight scales are designed to be free floating. The internal structure consists of a parallelogram, which causes the scale to follow a specific deflection path when weight is added to the scale. If the scale is leveled properly, this path is approximately (but not exactly) vertical. When two or three scales are linked by a platform, the application of weight causes the scales to be forced apart or drawn together, depending on the misalignment between the scales. Furthermore, the platform usually deflects, introducing another component of misalignment.

MULTIPLE POINT WEIGHING METHOD

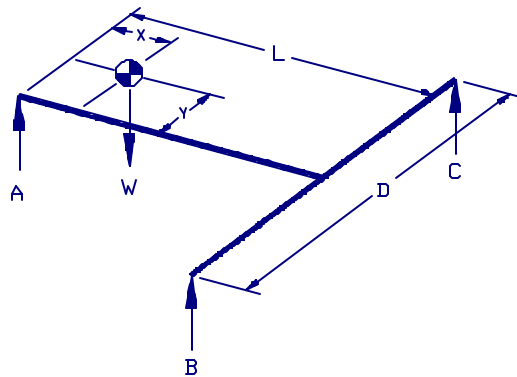

To determine part weight (W) and CG coordinates X and Y, three force transducers are typically used to support a frame which in turn supports the test part.

$$W = A + B + C \quad \text{where A, B, and C are force readings on the three force transducers.}$$

To determine CG, take moments about A

$$\Sigma M_x = (B+C)L - WX = 0$$

$$\Sigma M_y = \frac{CD}{2} - \frac{BD}{2} - WY = 0 = \frac{D}{2}(C-B) - WY$$

$$X = \frac{(B+C)L}{W} \quad -$$

$$Y = \frac{(C-B)D}{2W}$$

where X and Y are the CG coordinates. If all three scale outputs are set to zero when fixturing is in place, the equations above can be used to determine the CG location of the test part. In practice, tare readings are subtracted from the part.

The problem is that even a small error due to side load translates to a big CG error. Assume that

$$D = 60 \text{ inch}$$

$$\text{Side load error} = 2\% \text{ of weight } W$$

Then

$$Y = 0.5 \times 60 \times 0.02 = 0.060 \text{ inch}$$

Note: Aircraft weighing generally involves three point measurement. There are two reasons why side load errors are minimized in this process:

1. The scales which are used are specially designed to minimize side load errors.
2. As the aircraft is rolled onto the weight platforms, the rolling action tends to minimize the side load. In some instances, aircraft are rolled back and forth to further reduce this effect. This situation differs from the use of a solid platform which is coupled directly to the three scales.

ABOUT THE AUTHOR

Richard Boynton is President of Space Electronics, Inc., Berlin, Connecticut, a company he founded in 1959. Space Electronics, Inc. manufactures instruments to measure moment of inertia, center of gravity, and product of inertia. Mr. Boynton has designed many of the mass properties measuring instruments manufactured by Space Electronics. He holds a B.E. degree in Electrical Engineering from Yale University and has completed graduate studies in Mechanical Engineering at Yale and M.I.T. He is the author or co-author of over 69 papers, including 30 papers presented at SAWE International Conferences and 3 papers presented at Regional Conferences. He is the author of the SAWE Recommended Practice for Standard Coordinate Systems for Reporting the Mass Properties of Flight Vehicles. Mr. Boynton has been a member of SAWE for over 30 years and is currently Director of the Boston Chapter. In 1992 he was elected a Fellow and in 1998 was elected an Honorary Fellow of the SAWE. Mr. Boynton is a member of the Society of Automotive Engineers, where he serves on the Balancing Subcommittee (which is currently involved with setting standards for jet engine balancing).