

A New High Accuracy Instrument for
Measuring Moment of Inertia and
Center of Gravity

By
Richard Boynton, President
and
Kurt Wiener, Assistant Chief Engineer

Space Electronics, Inc.
81 Fuller Way
Berlin, CT 06037

For presentation at the
47th Annual Conference
of the
Society of Allied Weight Engineers

Detroit, Michigan, 23-25 May 1988

Permission to publish this paper, in full or in part, with full
credit to the authors may be obtained by request to:

S.A.W.E., Inc.
344 East "J" Street
Chula Vista, California 92010

The society is not responsible for statements or opinions in
papers, or discussions at its meetings.

Abstract

This paper describes a new class of mass properties measuring instruments which exhibit performance that is 10 to 100 times better than any measuring machine of conventional design. This extraordinary magnitude of improvement is the result of a new technology: high speed closed-loop moment sensing. The basic concept is similar to the old re-balance CG instruments which contained a counterbalance weight and a motor drive to reposition this weight so that a moment balance was achieved. However, unlike the old “soft” technology which was very slow and unstable, the new technology achieves balance in less than one second, and because of the high loop gain, is also very stiff and stable. Unlike most technology improvements, there is no tradeoff. The new concept improves all of the performance criteria: sensitivity, dynamic range, linearity, stiffness, and overload protection. Dynamic range and sensitivity are increased by a factor of 100. Actual transducer dynamic range is 200,000 to 1! Linearity is improved from .05% to 0.001%. Stiffness is increased by a factor of 5! And finally, the new design has an overload capability at least 10 times as great as the conventional technology. This sounds too good to be true, and at first we were skeptical, but extensive tests on a number of instruments of different sizes have failed to show up any disadvantage to the new method.

Summary

Prior to the discovery of high speed closed-loop moment sensing, the dynamic range of a moment measuring transducer in a CG instrument was limited to about 2000 to 1, and linearity was limited to about 0.05%. Attempts to improve either dynamic range or linearity were hampered by the basic trade-off between stiffness and sensitivity. If the

moment transducer was made softer to obtain greater dynamic range, then the test object would lean away from the measurement axis, and the system would rock back and forth for several minutes before the reading became steady, resulting in excessively long measurement time. For tall test objects, this soft transducer system became unstable unless a vertical counterbalance was used. If the moment transducer was made stiffer to eliminate these problems, then thermal expansion of the transducer and drift in the electronics caused major errors. About a factor of two improvement could be made by using AC excitation with a load cell transducer, since the AC signal eliminated DC drift and placed the frequency of the signal in the low noise region of the amplifiers. Other techniques involving matched pairs of transducers could reduce the effects of thermal expansion by another factor of two. However, the increased complexity of these features made it questionable whether the small improvement in dynamic range was worthwhile.

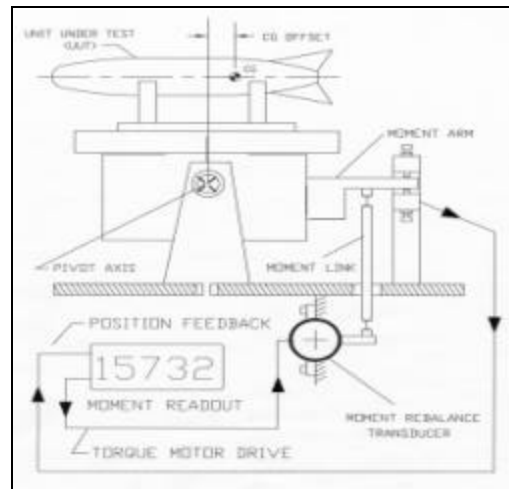

Figure 1 – Active Moment Transducer
Circuit measures current required to center moment arm. This current is proportional to CG offset.

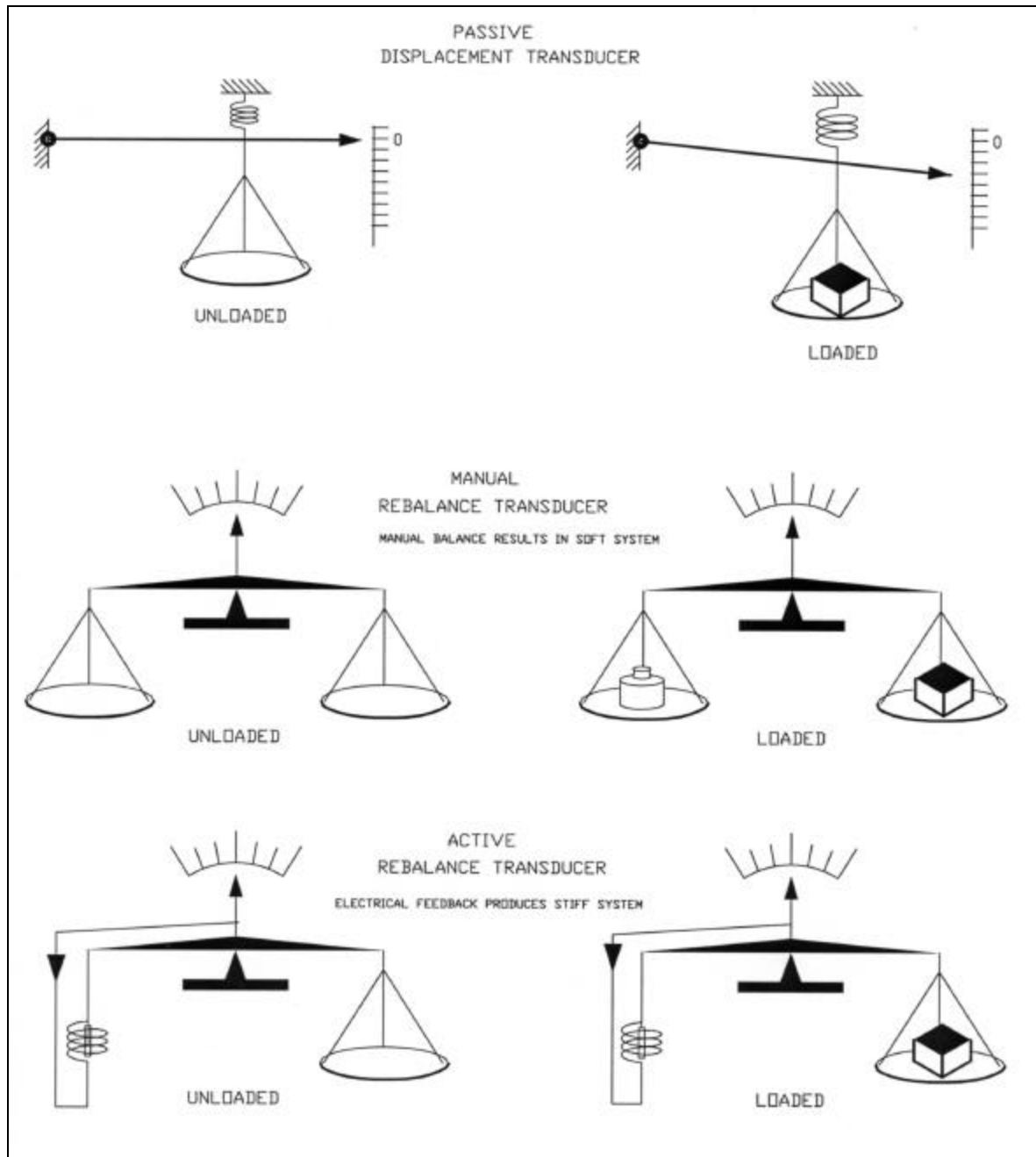

Figure 1A – This shows the three basic moment measuring concepts used in center of gravity instruments. The passive transducer (load cell, moment cell, or torsion rod with LVDT) deflects when a torque is applied. Linearity depends on the mechanical characteristics of a spring. The axis of the instrument tilts under the influence of the offset moment. The manual rebalance transducer is linear and accurate because the unbalance is counteracted by an equal and opposite moment, restoring the mechanism to its original position. However, this type of system is very soft, requiring vertical counterbalance to prevent instability. Measurement time is quite long. The active rebalance transducer uses electrical feedback to accomplish the same goal as the manual transducer. High loop gain results in a stiff system which is also very fast.

Conventional instruments use a load cell or other displacement type transducer to measure the unbalance moment. All of these techniques require that the transducer deflect in order to produce an output. This type of technology employs a passive sensor. The new method disclosed in this paper uses an active transducer. Rather than allowing the sensor to deflect, an equal and opposite torque is applied to the measuring system to hold the measurement axis exactly vertical even though the overturning moment due to the test object CG offset is trying to tilt the axis. If a high loop gain is used, then the system is almost infinitely rigid. The torque output to return the system to its neutral position is measured rather than measuring the deflection of a metal spring (for example, a load cell). Since the voltage required to excite a torque motor is in the order of 25 volts (as contrasted with the 25 millivolt output of a load cell), the electrical noise is insignificant.

For practical reasons, it is necessary for the traditional deflection type transducer to be sized with a safety margin between the full scale moment of the instrument and the point where the transducer yields. This means that the full dynamic range of the transducer cannot be taken advantage of, since some of this range is used up by the safety factor. The active transducer described in this paper does not have this limitation. If this new transducer is overloaded, the torque motor gently deflects until the system contacts a rugged stop. Since the transducer cannot be overloaded, there is no need to throw away part of the dynamic range to provide a safety factor against possible damage.

Instrument Description - When measuring explosive devices, or test parts which are difficult to fixture, it is often desirable to use an instrument which measures both Moment

of Inertia (MOI) and Center of Gravity (CG) without the need for re-fixturing the test part. For such measurements, the test object center of gravity will rarely be coincident with the measurement axis. This means that the instrument used to measure the combined moment of inertia and center of gravity must be capable of measuring moment of inertia through an axis which is considerably separated from the principle axis. The instruments described in this paper are capable of high accuracy over a wide range of test object weight and moment of inertia, and permit the measurement of moment of inertia about an axis which does not pass through the center of gravity of the test object. An inverted torsion pendulum provides time period data which can be easily related to test object moment of inertia, while center of gravity is determined by measuring the offset moment and dividing by the weight of the test object.

Combined mass properties measurements are best made using a system incorporating gas bearings to support the test part and define the axis of rotation and either a (spherical) gas bearing or crossed web flexures to define the pivot axis for measuring offset moments. It has long been recognized that the spherical gas bearing offers the combination of extremely low friction to both rotational and overturning moments, plus extremely high stiffness to forces at right angles to the rotational axis. Crossed web flexures also afford high stiffness and low friction in pivot applications that involve very small rotational displacement. Very small rotational displacements are assured by using moment restoration transducers which have an effective stiffness approaching infinity. The specific selection of gas bearings and/or flexures is largely a function of application i.e. test part weight, MOI, probable CG offset,

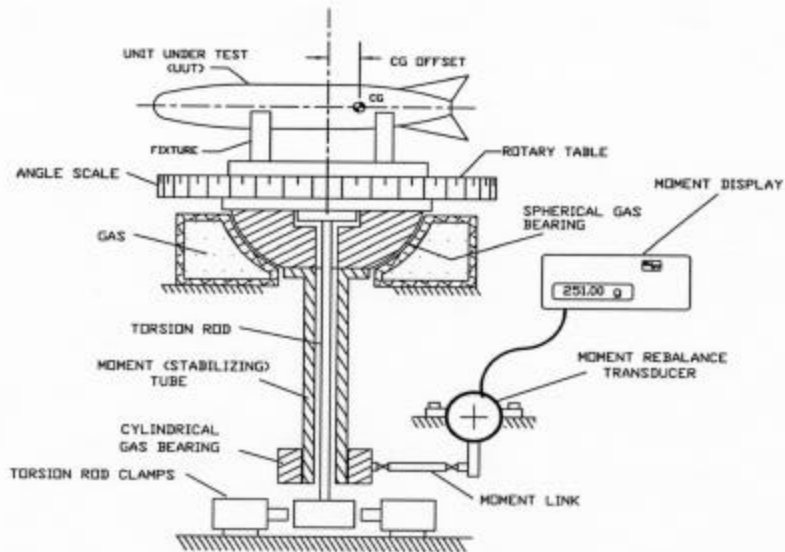

FIGURE 2A
CG & MOI Instrument Using
Spherical Gas Bearing Pivot

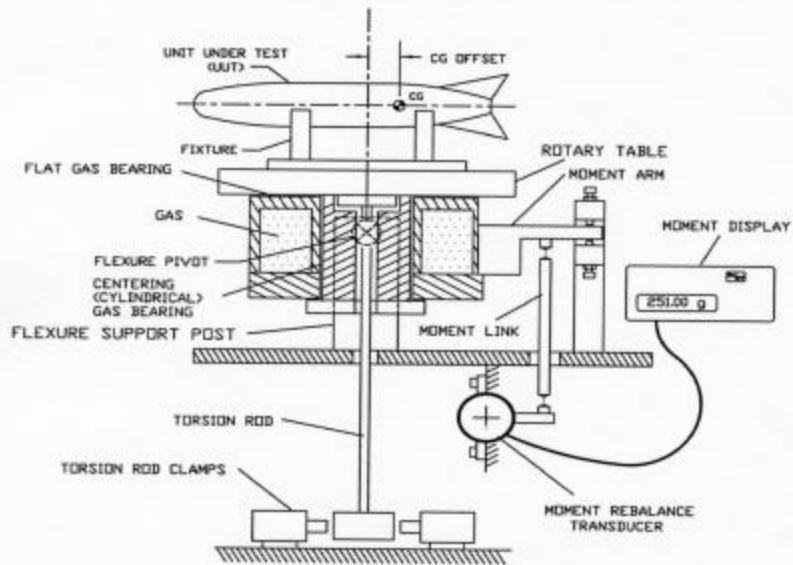

FIGURE 2B
CG & MOI Instrument Using
Crossed-Web Flexure Pivot

Figures 2A and 2B

and required accuracy. When properly designed, the pivot axis remains fixed, independent of the weight of the test part or the location of the test part center of gravity. Pivot axis definition of better than ± 0.0005 " is readily obtained.

The two basic mechanical configurations used in the instruments described in this paper are illustrated in figure 2A and 2B.

In figure 2A the test object is supported by a spherical bearing (using a test fixture if necessary). If no additional restraint mechanisms were used on this spherical bearing, then it would be free to turn about any axis which passed through the center of the sphere. In order to convert this basic bearing into a useful mass properties instrument, a restraining method must be employed which keeps the test surface horizontal while measuring moment of inertia and center of gravity. In our instrument, this restraint is provided by a hollow tube which extends from the base of the spherical bearing. The lower end of this hollow tube is attached to a second (cylindrical) gas bearing which is connected through a moment restoration transducer string to the rigid instrument base structure, so that the deflection of this lower bearing is extremely small, even when large overturning moments are applied to the test surface of the instrument. A torsion rod extends from the upper surface of the bearing (the test table) to a clamping mechanism at the bottom of the rod. When this clamping mechanism is released, the spherical bearing is free to turn about the vertical axis.

In figure 2B, a flat gas bearing supports the test part and a cylindrical gas bearing defines the rotational axis. The bearing and test table assembly is mounted on crossed web flexures which define the pivot axis. A moment arm extends from the gas bearing body and is connected through a connecting rod to the

moment restoration transducer. The torsion rod is mounted similar to that in figure 2A. The measuring principles described below are the same for both configurations. For convenience, the following discussion will refer to the spherical bearing configuration (fig. 2A).

Center of Gravity Measurement

The center of gravity of the test object is determined by measuring the overturning moment at two or more rotational angles of the bearing. The most accurate measurements are made using the technique shown in figure 3. By averaging the moments at rotational angles displaced by 180 degrees, certain errors are eliminated.

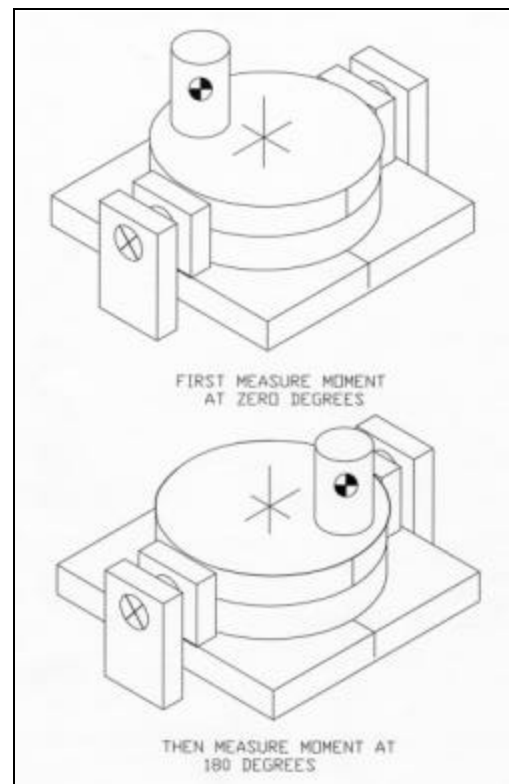

Figure 3

Leveling and Zero Offset are eliminated by averaging moments at 0 and 180 degrees.

In order to obtain maximum sensitivity from the instrument, a dual range moment transducer is used. This type of transducer senses small displacements due to offset moments and applies a restoring torque to reposition the test table to its initial unloaded position. This type of transducer permits a dynamic range of 200,000 to 1 or better.

It should be pointed out that by virtue of the rotation of the bearing during measurement, it is possible to eliminate many of the sources of error which exist in static CG measuring systems. Unbalance in the fixture can be eliminated by turning the bearing and adding counterweights or otherwise adjusting the fixture until a constant moment reading is obtained for all angles of rotation. Zero shift of the force measuring system does not result in an error since moment measurement is relative i.e. measurements are made at 0° and 180° and the difference in moment is used to compute the CG location of the test part. Similarly, errors in the leveling of the test surface will result in equal readings for angular locations spaced 180° apart. The true CG location can be mathematically determined from the two readings, or the instrument can be re-leveled and additional data taken. This permits even tall thin parts to be accurately measured. Since both axes of CG measurement are determined using the same transducer, only a single calibration point is needed to determine the moment sensitivity of the instrument. Turning the instrument 180° detects any hysteresis changes in the transducer system. A perfect system results in identical moment readings but opposite in direction (sign) for a 180° shift.

True CG offset of test part will result in an offset moment which changes as a function of test table angle. Maximum negative moment and maximum positive moment will be displaced by an angle of exactly

180° . Zero moment readings will be obtained 90° from these maximum values.

Isolating tilt angle error from CG offset

Figure 4a illustrates the effect of the lean of the interface surface on the accuracy of center of gravity measurement. Even with a center of gravity instrument whose accuracy is better than 0.001", if the interface surface is not precisely perpendicular to the gravitational axis, then the test part center of gravity can be displaced by a considerable amount. This offset CG due to the lean of the table can be distinguished from true CG offset by turning the test surface through an angle of 180° . As the drawing indicates, an apparent CG offset due to the tilt of the test surface will not change as the table is turned, whereas true CG offset (figure 4b) of the test part results in an offset moment which changes as a function of test table rotation angle.

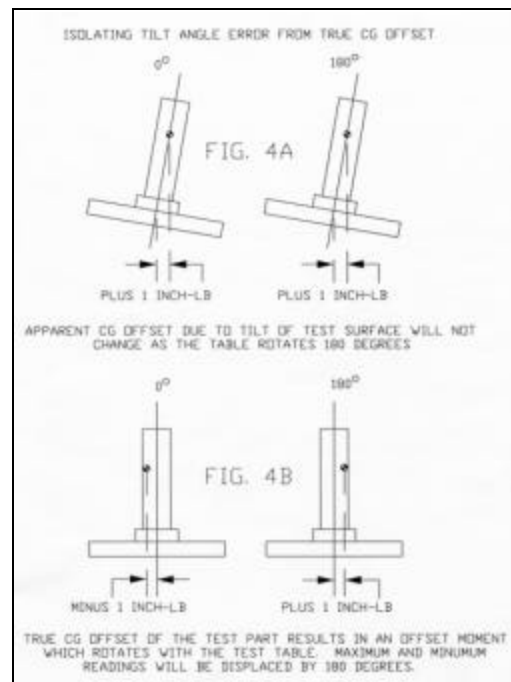

Figures 4A and 4B

PERFORMANCE IMPROVEMENT DUE TO ACTIVE MOMENT TRANSDUCER

	OLD PASSIVE TECHNOLOGY (Model KGR2000)	NEW ACTIVE TECHNOLOGY (Model KSR2000)
CG error:		
1000 lb part	0.001 inch	0.0005 inch
100 lb part	0.010 inch	0.0012 inch
10 lb part	0.100 inch	0.0075 inch
5 lb part	0.5 inch	0.075 inch
Full Scale Moment	2000 lb-inch	2000 lb-inch
Sensitivity	1 lb-inch	0.07 lb-inch
Linearity	0.1%	0.005%
Maximum moment (before damage)	2500 lb-inch	20,000 lb-inch
Deflection error	0.001" per 20" height	0.0002" per 20" height

INSTRUMENT SIZES AVAILABLE

MODEL	Recommended Payload Weight Range (lb)	Full Scale Moment (lb-in)	MOI Accuracy (lb-in ²)	CG Accuracy (lb-in)
KSR330-6	0.25 - 20	6	0.1% + 0.03	0.1% + 0.0005
KSR330-16	1 - 40	16	0.1% + 0.03	0.1% + 0.001
KSR330-60	3 - 120	60	0.1% + 0.03	0.1% + 0.003
KSR1320-150	50 - 800	150	0.1% + 0.2	0.1% + 0.01
KSR1320-300	50 - 800	300	0.1% + 0.2	0.1% + 0.02
KSR1320-600	100 - 1320	600	0.1% + 0.2	0.1% + 0.04
KSR1320-1500	100-1320	1500	0.1% + 0.2	0.1% + 0.06
KSR2200	100 - 2200	2500	0.1% + 0.7	0.1% + 0.1
KSR6000	200 - 6000	5000	0.1% + 2	0.1% + 0.3
KSR8000	200 - 8000	5000	0.1% + 2	0.1% + 0.3
KSR13200	500 - 13200	8000	0.1% + 4	0.1% + 1.5
KSR17000	500 - 17000	16000	0.1 + 10	0.1% + 8
KSR20000	1000 - 20000	36000	0.1 + 10	0.1% + 8

Pivot Axis Error

The pivot axis on this instrument is a gas bearing. The gap in this bearing is typically less than 0.001"; the dynamic centering action of the choked orifices of the bearing result in a stability of pivot axis typically less than plus/minus 0.0002" over the full range of weight of test parts.

Moment Error

The unbalance moment in the instrument is measured using a moment arm and transducer. Linearity of the transducer is better than 0.001%. The lengths of the moment arm and transducer arm determine the moment amplification factor for the machine. The effective length of these arms remains constant within 0.01% provided the ambient temperature does not vary more than plus/minus 10° F. (Changes in ambient temperature will also change the dimensions of the test object and fixture, resulting in a shift in the center of gravity relative to the measurement axis of the instrument). Since the weight of the test object is supported by the pivot axis, not the moment transducer, the full scale range of the moment readout may be chosen for any desired accuracy by selecting the appropriate transducer and moment arm length. However, higher accuracy requires a smaller maximum overturning moment. The 180° rotation feature of the instrument eliminates any error that might be introduced by transducer zero shift. Since the resolution of the instrument is so high, useful readings can be obtained for moments as small as 0.01% of full scale, even with a single range transducer. Using proper calibration techniques and a dual range transducer, moment readings as small as 0.001% of full scale may be obtained.

Calibration Weights - Center of Gravity

Several certified and traceable calibration weights are supplied with these instruments. These weights, when placed in precisely located holes (certified and traceable), permit the creation of a precise overturning moment, and allow the computer to develop accurate calibration constants which correct the moment readout so that maximum accuracy is obtained for even small test parts.

System Rigidity

The spherical gas bearing combined with the stabilizing shaft and lower bearing results in an extremely rigid measuring system. Negligible error is introduced by system flexibility for test objects whose CG height is equal to or less than the maximum specified for each instrument size. Tall thin parts may result in a small shift in measured CG due to the deflection of the test part if the test part CG is not centered, or if there is considerable tilt to the instrument. This effect can easily be compensated for by simply centering the test part accurately and re-leveling the instrument after the test part has been mounted in place if leveling error persists.

Moment of Inertia Measurement

The instrument is converted to moment of inertia measurement by clamping the lower end of the torsion rod to create an inverted torsion pendulum. In this mode, the test surface of the instrument oscillates in a rotational sense about a vertical axis through the center of the test surface. Tare moment of inertia measurements are made by first measuring the time period (T_0) of oscillation with the test fixture mounted on the instrument (but without the test part). The test part is then mounted in the fixture and a

second time period (T_x) measured. The rotational moment of inertia for each of these two measurements may be computed by using the formula:

$$\text{Part \& Fixture MOI } I_x = CT_x^2$$

$$\text{Tare (fixture) MOI } I_o = CT_o^2$$

$$\text{Net (Part) MOI } I_p = I_x - I_o$$

$$\text{Therefore } I_p = C(T_x^2 - T_o^2)$$

where C is a calibration constant for the instrument, and is related to the torsional stiffness of the torsion rod. The moment of inertia of the test part is then computed by subtracting the total inertia from the tare inertia (the inertia without the test part mounted on the instrument).

Using this inverted torsion pendulum, accuracies as high as 0.01% have been achieved and measurement accuracies as great as 0.003% are possible using specialized measurement techniques (such as the averaging of ten readings and the use of calibration weights which duplicate the mass and moment of inertia of the test object).

Unlike hanging wires or other traditional moment of inertia measuring methods, this technique closely defines the axis of measurement and permits measurements to be made through an axis which does not coincide with the center of gravity of the test object, without introducing aberrant motions such as swaying or bouncing. Since the instrument is capable of determining CG location, moment of inertia measurements may be corrected to give the value which would be obtained if a measurement were made through the center of gravity. This correction consists of squaring the displacement (x) of the center of gravity from the measurement axis and multiplying

it times the mass of the test part (M). This axis of translation moment of inertia value (Mx^2) is then subtracted from the measured value to yield the value of moment of inertia through the test object center of gravity.

$$I_{cg} = I_p - Mx^2$$

Alternatively, the MOI of the part about any desired vertical axis can be calculated by adding the product of part mass (M) and the square of the displacement (R) between CG and the desired axis.

$$I_r = I_{cg} + MR^2$$

Effect of Test Part Weight

Since the weight of the test part is totally supported by the gas bearing and none of this force is applied to the torsion rod, the instrument is insensitive to test object weight and may be calibrated using a single test mass. The moment of inertia indication will then be linear over the full range of weight and moment of inertia specified for the instrument.

MOI Calibration Method

Two identical calibration weights are placed on the center of the rotary table and a tare measurement of oscillation period (T_o) is made. The two weights are then moved equal but opposite distances (R) from the center and a second oscillation period (T_x) is measured. The change in MOI is equal to the combined mass of the two weights (M) times the square of the distance (R). The calibration constant is:

$$C = \frac{MR^2}{(T_x^2 - T_o^2)}$$

Using this method, all effects of instrument MOI, and MOI of the masses about their own CG are accounted for and the

calibration constant is a function only of certified and traceable mass and distance.

Effect of Oscillation Amplitude

These instruments exhibit negligible change in oscillation period for differences in oscillation amplitude as great as 3 to 1. The highest accuracy versions of these instruments employ a second photoelectric sensing mechanism which re-sets the digital counter until a preset amplitude of oscillation is reached. Using this technique, the time period of oscillation is always measured at precisely the same oscillation amplitude, eliminating this variable. Averaging several readings further improves accuracy.

Minimum Moment of Inertia Which Can be Measured

The smallest moment of inertia which can be measured with a particular size instrument is primarily a function of the tare moment of inertia of the instrument. If the part inertia is 100 times the tare inertia of the instrument, then a small change in tare inertia will not appreciably affect accuracy. If the part inertia is 1/100th of tare inertia, then a 2σ change in ambient temperature will introduce a 0.5% error in the reading of the part inertia due to the small change in tare MOI which occurred after the tare measurement was made. This means that frequent re-calibration and tare measurement are necessary to get meaningful results if the test part moment of inertia is much smaller than 1/20th of the tare moment of inertia of the instrument.

Time period accuracy is another factor which limits the minimum MOI which can be measured accurately. A typical standard instrument has a time period accuracy of 1 part in 50,000. This results in negligible error for objects which are large relative to the tare MOI of the machine. If we limit our

measurement error to 0.25% of reading, then this time period limitation requires that the test object MOI be no smaller than 1/125th of the tare MOI.

Since the fixture adds to the tare inertia of the measuring system, its moment of inertia should be made as small as possible when measuring parts with small moment of inertia. For a maximum error of 0.25%, the total MOI of instrument and fixture should not exceed 35 times the MOI of the object under test.

Torsion Pendulum Theory

Consider the torsion pendulum of Figure 5a consisting of a disk of mass moment of inertia T lb-in-sec², restrained in rotation by a wire of torsional stiffness K in-lb/radian. If the disk is turned an initial angle θ^0 and sharply released, it will oscillate with damped harmonic motion as shown in Figure 5B. The period of oscillation will remain constant and the amplitude of oscillation will gradually decay to zero.

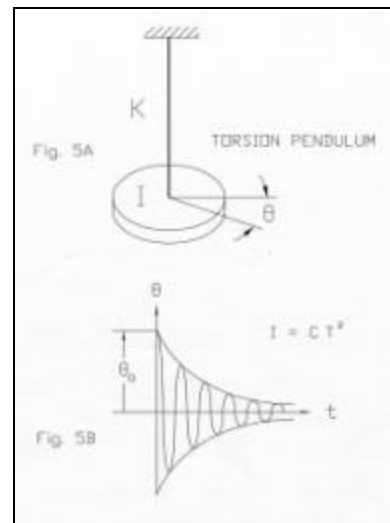

Figures 5A & 5B

For purely viscous damping proportional to angular velocity, the equation of motion will

be:

$$I\ddot{q} + B\dot{q} + Kq = 0$$

The solution to this differential equation is given below:

$$q = \underbrace{q_0 e^{-z\omega_n t}}_{\text{exponential decay}} \sin \underbrace{\left(1 - z^2\right) \omega_n t}_{\text{oscillation at a frequency } (1-z^2) \omega_n}$$

For very small damping, the torsion pendulum oscillates at its natural frequency "w", and the moment of inertia can be determined by the simple relationship:

$$T = C T^2$$

where C is a calibration constant which may be determined experimentally by measuring the period of oscillation with a known additional moment of inertia, or may be calculated from the relationship:

$$C = \frac{Kp^2}{4}$$

For significant damping, the actual period of oscillation is greater than the undamped natural period by an amount determined by the damping ratio "z". If the torsion pendulum is being used as an instrument to measure moment of inertia, then the measured moment of inertia will be greater than the true value. This error can be eliminated if the following equation is used in place of the previous equation.

$$T = CT^2 (1-z^2)$$

In order to make use of this equation, the value of the damping ratio, z, must be determined. This is accomplished by noting the rate at which the amplitude of oscillation decays. If we define the logarithmic decrement as the natural logarithm of the ratio of any two successive amplitudes, then

the log decrement, d, of the starting amplitude, O^0 , as compared to the peak amplitude O_n , after "n" cycles have elapsed is given by the equation:

$$d = \frac{1}{n} \ln \left[\frac{q_0}{q_n} \right]$$

For small values of z, the logarithmic decrement, d, can be related to z by the following relationship:

$$d = 2p z$$

If we now count the number of oscillations of our torsion pendulum, n, for a decay in peak amplitude of 10/1, we may combine equations and solve for the error resulting from viscous damping:

% error due to viscous damping: $100 z^2$

$$\% \text{ error} = \frac{(\ln 10)^2}{(2p)^2} \frac{100}{N^2} = \frac{13.41}{N^2}$$

graphical solution to this equation is given in Figure 6. To correct the measured value of moment of inertia, the amount shown on the graph should be subtracted from the measured value to yield the true value. Note that the error is insignificant if more than 50 oscillations are required for the amplitude to decay to one tenth of its original value.

Effect of Entrapped Air

A commonly overlooked source of error is due to the mass of entrapped air, especially in test objects which will operate in space, vented to vacuum. For example, if a satellite structural component has an internal new volume of 3 ft³, the mass of entrapped air nominal sea level conditions will be approximately .25 lb. If this volume is located at 100 inches from the rotational

axis of the satellite, an error of 2500 lb-in² is introduced. This may be significant enough to affect performance, particularly if the component itself has little mass.

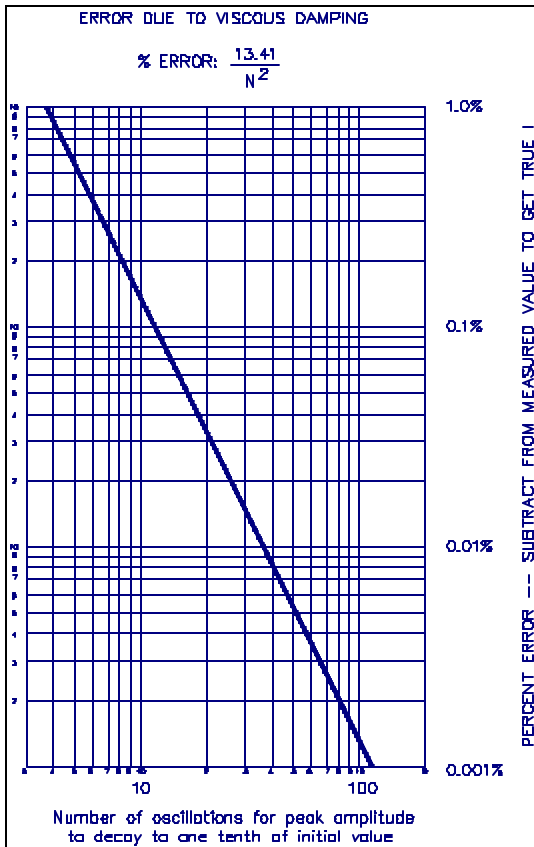

Figure 6

Leveling Error

As derived previously, the basic equation for a torsion pendulum is:

$$I = \frac{K_t}{4p^2} (T_1^2 - T_0^2)$$

In this equation, the torsion constant, K_t , is the spring rate of torsion rod. In a real torsion pendulum measuring a test part with an offset CG there is a second "spring" force, namely the gravitational pendulum due to slight errors in the level condition of gas bearing. If the torsion spring is removed from the system, this effect can easily be observed: the test part will oscillate back

and forth and eventually come to rest with the test part CG at the low point of the bearing. The effective spring rate of this gravity pendulum will depend on:

- (a) The amount of tilt of the gas bearing.
- (b) The weight of the test part.
- (c) The CG offset of the part (horizontal distance between CG and rotational axis).

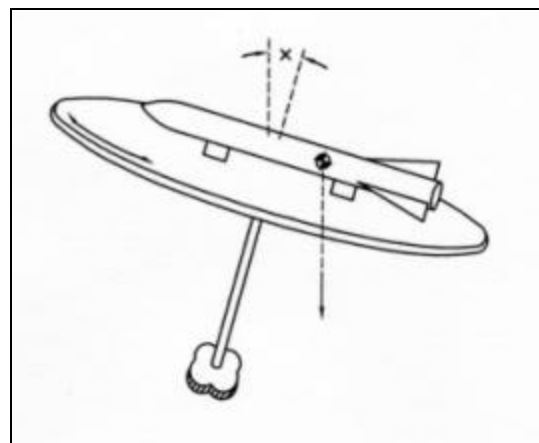

Figure 7

An error in the level condition of the torsion pendulum causes a gravity pendulum error.

This gravity pendulum error can add to or subtract from the spring rate of the torsion rod, depending on the angular location of test part CG relative to the low point of the table. If the low point is 90° from the CG, then the tilt angle will apply a static torque to the torsion rod. This displaces the midpoint of oscillation, resulting in a small error due to amplitude decay. A large tilt under these conditions could twist the torsion pendulum to the point that the timing sensor no longer functioned. For a small angle of oscillation, a simple "grandfather clock" pendulum has a torsional stiffness.

$$k = Md \quad \text{in - lb / rad}$$

where M is the weight of the test part and d is the CG offset.

For the torsion pendulum, the torsional stiffness due to an angle error in the level condition, X, is

$$k_G = Md \sin X \quad \text{in - lb / rad}$$

The equation for the torsion pendulum with the worst case orientation of tilt now becomes:

$$I = \frac{(K_t + Md \sin X)}{4p^2} (T_1^2 - T_0^2)$$

To numerically evaluate the effect of this error term, consider this example:

Test Part Radius of Gyration = 10.000 inches

Test Part Weight = 100lbs.

Cg Offset, d, = 3.000 inches

Torsion Rod Stiffness, K_t , = 150 lb-in/radian

Leveling error, X = 0.0005 radian

Then

Moment of Inertia Accuracy

$$\text{Error} = \frac{Md \sin X}{k_t} = \frac{(100)3 (.0005)}{150}$$

$$\text{Error} = 0.1 \%$$

Effect of Internal Damping in the Torsion Pendulum

There are two common sources of damping in a torsion pendulum used to measure moment of inertia; first, the windage of the test part contributes some damping (depending on the diameter and the shape of the part); second, the centering bearing and the internal losses in the wire damp the oscillations. An important observation can be made with regard to internal damping. Since the effect of a given amount of damping, B, is inversely proportional to the moment of inertia of the oscillating assembly, increasing the amount of moment of inertia will decrease the effect of a given amount of damping. This observation assures us that if the basic damping of the torsion pendulum when measuring the tare moment of inertia is small enough so that its resulting change in time period can be neglected, then the damping of the basic torsion pendulum can also be neglected when measuring a test part. Or, stated very simply, if more than 100 oscillations are required for the peak amplitude of the torsion pendulum to decay to 1/10 of its original value, when no object is mounted on the torsion pendulum, then the effect of internal damping in the torsion pendulum can be neglected. This, in fact, is the case for all gas bearing torsion pendulums which have been constructed by Space Electronics.

A second observation can also be made with regard to the effect of damping. Since the change in the apparent moment of inertia is a function of the ratio of the viscous damping to the critical damping for the system, and since the critical damping is proportional to the square root of the torsion spring constant, then increasing the torsional spring constant will reduce the effect of viscous damping, whether it be internal in the instrument or due to windage of the test part. This means that a stiffer torsion pendulum will exhibit less error due to damping. This observation does not hold true when the velocity of the oscillating

pendulum reaches the point where the air becomes turbulent.

The effect of windage damping may be eliminated by operating the instrument in a vacuum. Operating the instrument in a vacuum will increase the pressure drop in the gas bearing and result in altered lifting capability of the bearing. If such use is contemplated, then it should be specified when the instrument is originally purchased, so that the bearing may be designed for this environment.

Factors Affecting Torsion Spring Stiffness

Most sources of error are minimized by making the torsion spring as stiff as possible. The error due to viscous damping decreases in direct proportion to the torsion spring constant. So does the error due to the gravity force with an offset CG (when the axis is not exactly vertical), drafts, seismic perturbations, and non-viscous friction. The stiffness of the torsion spring is limited by the following factors:

1. The tare time period must be long enough to permit the required accuracy (i.e. a limit exists on the response time of the sensing mechanism and on the minimum resolution of the period counter).
2. If the spring is too stiff, then the oscillation period of the torsion pendulum may approach the first resonant frequency of the test part. This would cause the test part to de-couple so that the instrument measured only part of the moment of inertia. (Or it could result in fatigue or failure of the test part).
3. A high resonant frequency of the torsion pendulum places greater demands on the rigidity of the test fixture, and on the repeatability of fastening the part into the test fixture.

4. To prevent fatigue aging of the torsion spring, it must be deflected well below its elastic limit. For a stiffer spring, this generally means that the amplitude of oscillation of the torsion pendulum must be made increasingly smaller to stay within this limit. This in turn affects the timing accuracy indirectly, since the displacement error of the sensing mechanism represents a greater proportion of the period of oscillation.

5. As the torsion spring is made more stiff, a given initial displacement of the torsion pendulum will result in greater velocity at the midpoint of oscillation. When testing parts of large diameter and irregular surface area, it is possible that the windage friction will not any longer be viscous due to turbulence. This parameter is the most difficult to evaluate since the stiffness of this spring may be minimizing the error due to windage drag at a faster rate than the turbulence is introducing non-linearities. Except for extremely unusual parts such as small satellites with extended solar panels, it is probably true that the increase in windage damping is outweighed by the benefits of the stiffer torsion rod.

6. The ratio of vertical rocking resonant frequency to torsional resonance must be at least 10/1 to prevent any excitation of this mode.

The ideal torsion stiffness results in a time period of oscillation of 0.3 seconds for the tare, 1 second for the minimum moment of inertia, and 30 seconds for the maximum moment of inertia. It should be pointed out that it is a relatively easy matter to change the diameter of the torsion rod without affecting any of the other parts of the instrument (except the inside diameter of the wire clamp) so that this torsion stiffness could easily be changed if experimental data

indicated a need.

Most people intuitively feel that the time period could be longer than what is indicated by the mathematical analysis. We think that this intuitive feeling comes from the early days when torsion pendulums were timed by a stop watch and the timing accuracy was the largest source of error. Experimental data taken on over one hundred pendulums has always confirmed our theory that the stiffer torsion rod yields the most accurate results.

Centering Bearing

A stiff centering bearing is essential to the accurate operation of the torsion pendulum.

1. It eliminates the horizontal motion of the pendulum which would alter the relationship between the moment of inertia and time period of oscillation.
2. It greatly reduces the sensitivity of the pendulum to seismic motions due to external vibrations.
3. It eliminates the most significant source of timing error--the inability of any sensing device to discriminate between rotational motion and motion in a purely horizontal sense.
4. It accurately defines the axis of rotation of the pendulum permitting definition of the measurement axis.
5. When the part has a center of gravity which is not located directly on the rotational axis, it prevents the part from rotating about the center of gravity and it also prevents a bending moment being applied to the torsion rod due to the torque produced by the offset CG.
6. Most important, the bearing keeps the rotational axis vertical minimizing gravity

errors with offset CG.

The ideal bearing should have no runout, minimum viscous damping, and no sliding friction, and infinite rigidity to both horizontal and bending forces. A gas bearing has both the smallest runout and the smallest amount of friction of any known type of bearing. If the bearing is composed of simple shapes, then the axis of rotation can be more closely defined than with any other bearing system. In actual practice, the stiffness of the bearing is limited by two factors: the tare of the inner race of the bearing which increases with both length and diameter, and the forces introduced by the flow of gas in the bearing. These forces can be either of a motoring type in which the gas flows in a circle and produces a constant torque in one direction, or of a self-centering type in which there is a null position, or the forces can be oscillatory in a horizontal mode due to pneumatic hammer instability. These bearing forces can be minimized by keeping the gas pressure to a minimum (i.e. employing a conservative design) and by using a certain design technique which minimizes the chance of instability and makes it possible to control the flow characteristics of the bearing very carefully.

Summary of Moment of Inertia Error Sources

The ideal torsion pendulum has three characteristics:

1. Its motion is purely rotational about a well defined axis.
2. The only forces acting on the torsion pendulum are the rotational stiffness of the torsion spring and the inertia of the rotating assembly plus a relatively small amount of pure viscous damping.
3. The method of timing the period of

oscillation exhibits a high degree of repeatability and linearity.

Unwanted motions of the torsion pendulum include horizontal motion due to an unbalance created during the initial starting of the oscillation, an external source of vibration, the natural unbalance force which is created when an object is rotated about an axis other than its principal axis; vertical motion due to unbalance in starting and/or external vibrations, and rocking motion due to starting unbalance, external vibrations, or dynamic unbalance in the rotating system which includes the torsion pendulum and the test part. External forces which are undesirable include: gravity pendulum forces which result when the part center of gravity is not on the rotational axis and the rotational axis is not exactly vertical; the increase in measured MOI due to entrapped air within the objects under test (significant for object which fly in the void of space); viscous damping due to windage (which will vary as a function of the external dimensions of the test part); drafts, seismic forces which occur when the center of gravity is offset from the rotational axis and the structure of the torsion pendulum is subject to external vibration; and non-viscous friction in the bearing of the torsion pendulum. Absolute calibration of timing accuracy, linearity of timing accuracy, and long term stability are of significance. The very close tolerance required of the instrument, however, places extreme demands on the repeatability and short term stability of the method used for timing of the period of oscillation. The linearity of the torsion spring has not been listed as a source of error, since it is possible to time the period of oscillation at a certain pre-established amplitude. In actual practice, however, the torsion spring is generally quite linear because of the symmetry of the torsion pendulum configuration and the fact that the spring must be operated well below its elastic limit

to prevent changes in spring constant with use.

Errors can be minimized by using a very stiff low friction bearing and by making the torsion spring as stiff as possible. The stiffness of the bearing is limited by the tare moment of inertia of the bearing and by the motor forces of the bearing. The center of gravity of the test part should be located as closely as possible to the rotational axis of the torsion pendulum.

Fixturing Error

Although this source of error is not a factor in the machine itself, the total measurement error is seriously affected by the ability of the test operator to position the object under test accurately relative to the measurement axis of the machine. The design of fixtures is discussed in the SAWE paper entitled *Spin and Static Balance Fixtures* by Richard Boynton and L.G. Hollenbeck (Paper number 1667, published May 1985).

Fixturing accuracy is of minimal importance when measuring the moment of inertia of test objects (unless the object is tall and thin). The reason for this is that the error is proportional to the ratio of the square of the fixturing error relative to the square of the radius of gyration of the object. Since the radius of gyration of the object is usually large relative to the fixturing error, squaring these two numbers results in a very small ratio. For example, if the fixturing error is 0.010 inch and the radius of gyration is 10 inches, then the moment of inertia measurement error is only 0.0001%!

Center of gravity accuracy is equal to fixturing accuracy. If the fixturing error is 0.010 inch, then the resulting CG error is also 0.010 inch. When measurements are made on a machine with a 0.001 inch maximum error for the weight of the object

being measured, then the fixturing error is the predominate source of error.

Instrument Foundation

Users of spin balance machines have grown to expect that the mass properties machine will require a heavy concrete block for optimum performance. This is true of a spin balance machine, since this type of machine requires an "infinite" mass to react against horizontally so that centrifugal forces are applied to the transducers while the unit under test is spinning. This same heavy block is not required for the mass properties machines described in this paper. All that is needed is a concrete floor on ground level which is sufficient rigid so that it will not deflect under the weight of machine and test object. Generally an ordinary 6-inch thick concrete floor is sufficient. It is desirable to locate the machine in an area that is free from vibration and drafts.

Computer Control

This instrument is supplied with an on-line microcomputer that controls the operation of the instrument and also provides a hard copy print out of the test data. Custom programs can create specific report formats or instruct the machine operator where to add correction weights (ballast) to adjust the center of gravity so that it is coincident with the flight (geometric) axis.

Conclusions

A dramatic discovery by the engineers at Space Electronics has resulted in a new class of mass properties measuring machines whose center of gravity accuracy is 10 to 100 times better than the previous versions of these instruments. This has reduced measurement error to a point where fixturing error is the limiting factor. One machine can now measure a range of test

object sizes previously requiring two different size machines. The new more accurate machines have the additional advantage that they are much more resistant to accidental overload than the older less accurate machines.

ABOUT THE AUTHORS

Richard Boynton is President of Space Electronics, Inc., Berlin, Connecticut, a company he founded in 1959. Space Electronics, Inc. manufactures instruments to measure moment of inertia, center of gravity, and product of inertia. Mr. Boynton holds a B.E. degree in Electrical Engineering from Yale University and has completed graduate studies in Mechanical Engineering at Yale and M.I.T. He is the author of over 40 papers, including 11 papers presented at past SAWE conferences. He has designed many of the mass properties measuring instruments manufactured by Space Electronics. Also, Mr. Boynton is the Chief Executive Officer of Mass Properties Engineering Corporation, and is a professional folksinger.

Kurt Wiener is Assistant Chief Engineer of Space Electronics, Inc. Mr. Wiener holds a B.S. in Mechanical Engineering from M.I.T. and a M.S. in Industrial Education from Central CT State College. He is a former Associate Professor of Mechanical Technology at Vermont Technical College. His previous work includes machine and control system design, and teaching these topics in industry.