

XR Series

Moment of Inertia Measurement Instruments



Description

We make six types of moment of inertia instruments covering a range of prices and accuracies. The XR Series have been designed for general use where a reliable well built instrument with high accuracy (0.25%) is required.

Three standard models are available for test parts with MOI's as small as 0.002 lb-in² up to parts weighing 250 lbs. In addition to its use as a design tool, this instrument is fast enough for use in line for production quality analysis.

We offer optional interfacing and software to display instructions

to the operator, acquire data from the instrument, calculate results, and print a report of results.

Technical Advantages

These instruments employ a patented technique which we call the torsion flexure, illustrated on the simplified drawing on the right.

Since the weight of the test part is supported by a torsion rod, negligible damping occurs in the restraint system. This design results in an inverted torsion pendulum which is less expensive than a gas thrust bearing pendulum and has a lower tare inertia. The hollow tapered output shaft of the instrument accepts a range of precision collets and test fixtures.

Selecting Instrument Size

There are three factors to consider in the choice of instrument size:

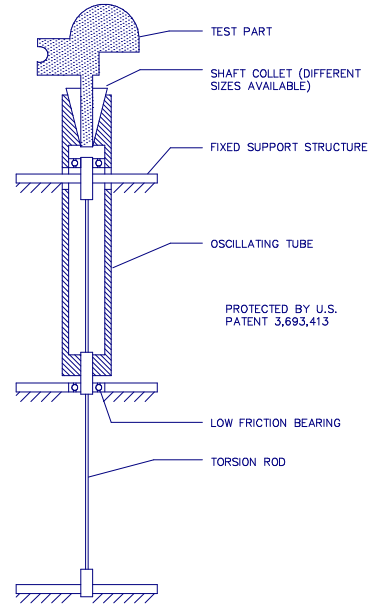

1. Maximum Weight of Test Part and Fixture. There is no limit on maximum moment of inertia.
2. Tare Moment of Inertia, which affects the smallest moment of inertia that can be measured with rated accuracy.
3. Maximum Center of Gravity Height of the Test Object.

Technical Specifications

	Model XR10	Model XR50	Model XR250
Payload Weight Capacity (including test part and fixture)	10 lb	50 lb	250 lb
Maximum CG height (payload weight at CG height)	10 lb @ 10"	50 lb @ 20"	220 lb @ 40"
Overturning Moment	15 lb-in	130 lb-in	750 lb-in
Tare Moment of Inertia	0.014 lb-in ²	0.4 lb-in ²	6.0 lb-in ²
MOI Accuracy (% of reading + lb-in ²)	0.25% + 1x10 ⁻⁵	0.25% + 2.5x10 ⁻⁴	0.25% + 1x10 ⁻³
Interface is a collet. Diameter:	0.375 in	0.750 in	1.250 in
Calibration hardware	Included	Included	Included